

RaceGrade

Document Number		RG_SPEC_0030	
Title		RaceGrade APT-G2-DTM Pressure Transducer	
Revision	Date	Prepared By	Change History
1.1	8/26/14	Hannah Westbrook	Initial release
1.3	7/23/15	Hannah Westbrook	Updated Connector options and Ranges available

Introduction

This APT-G2-DTM Pressure Transducer produces a DC voltage proportional to the pressure reading. It provides accurate and repeatable sensor readings by accounting for the effects of temperature, hysteresis and non-linearity. Featuring a wetted stainless steel design, it is compatible with all fluids and is hermetically sealed with an IP 67 ingress rating. It comes with a 3/8-24 UNJF3A (-3AN) as the pressure port, and a 3 pin DTM connector. Multiple pressure ranges are available.

** This sensor is ambient referenced and should not be used for manifold air pressure**

Part #	Range**
M APT G2 DTM 100	0.0 to 100 PSI Absolute
M APT G2 DTM 150	0.0 to 150 PSI Gauge
M APT G2 DTM 200	0.0 to 200 PSI Gauge
M APT G2 DTM 2000	0.0 to 2000 PSI Gauge

Calibration: *Can only be wired in AV input

0.5v = Full scale minimum PSI

4.5v = Full scale maximum PSI

Specifications:

- Fitting: 3/8-24UNJF3A(-3AN)
- Output: 0.5 to 4.5 Vdc
- Supply: 5 +/- 0.5 Vdc
- Current: < 4 mA
- Temperature Range: -40°C to 125°C
- Total Error: 1.0 % of F.S. Pres
- Proof Pressure: 2 x F.S. Pres
- Burst Pressure: 5 X F.S. Pres
- Response time : < 1 ms
- Main Seal: Wetted Stainless
- Weight: 46 grams
- Random Vibration : 20g

Connection:

Mating connector: DTM-3SK**

pin 1 – 5v

pin 2 – 0v

pin 3 – signal

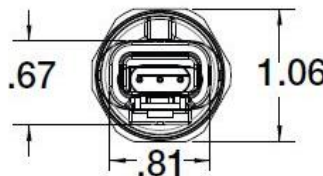
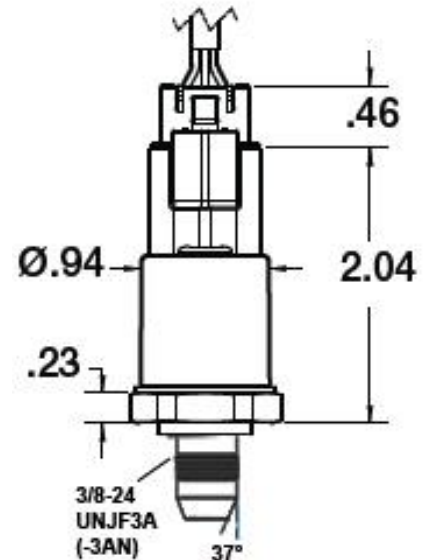

*****Warning:** Applying torque to the plastic sensor body will damage the unit which will void any return privileges. Do NOT hold the sensor by the body when tightening the fluid connection. Only use the stainless steel wrench hex to tighten the fluid connection to the sensor.

Note: Sensor should be mounted remotely to avoid engine vibration damage.

Contact RaceGrade for information on other termination and range options